

# HD-STM



# User Manual

## Horizon Global Electronics Ltd.

First Floor Office  
Allen House  
Edinburgh Way  
Harlow  
Essex  
CM20 2HJ

Phone: +44(0) 1279 417005  
Fax: +44(0) 1279 417025

**HORIZON**  
For a reliable solution!

Issue No. ??123/0.1  
Horizon Part Number: ??123

# Contents

---

Thank you for choosing to purchase the Horizon Global Electronics HD-STM installation meter. **Prior to using your meter for the first time please ensure that you have charged the battery for at least 8 hours.** Please read through this manual carefully to take advantage of the extensive features available on this product. Details regarding battery charging can be found on page \*\*. A printed quick start guide is also supplied with your meter.

## Introduction

Safety	Page 3
Your Meter	Page 4
Accessories	Page 5
Battery Charging	Page 6
Initial Start Up	Page 7
Set Up	Page 9

## Satellite

Satellite Finding	Page 11
Spectrum Display	Page 12
Constellation Display	Page 13
Custom Carrier	Page 14
DiSEqC (Switch / Motor)	Page 17
LNB & Cable Test	Page 19

## Terrestrial

Terrestrial Finding	Page 21
Terrestrial Menu	Page 22
Spectrum Display	Page 24
Constellation Display	Page 25
Mast Head Power (MHP)	Page 26
Terrestrial Scan UHF / VHF	Page 26
Step Through VHF / UHF	Page 27

## Logging

Data Logging	Page 29
--------------	---------

## Driver installation

Driver install	Page 32
----------------	---------

## Web downloads

Downloading files	Page 35
-------------------	---------

## File Transfer

File Transfer	Page 37
---------------	---------

## SD Memory

SD Card Management	Page 39
--------------------	---------

## System Warnings

System messages	Page 41
-----------------	---------

## Specification

Specification	Page 43
---------------	---------

## Warranty

Conditions of Warranty	Page 44
------------------------	---------

## Disclaimer

While every attempt is made to ensure that the settings available for all of the formats supported by the HD-STM are up to date and valid Horizon Global Electronics Ltd cannot be held responsible for the evolution of satellite and terrestrial broadcast technologies.

## Safety instructions



**This symbol is to alert the user to a potential hazard during the operation of this unit.**

- \* DO NOT expose this meter to rain or moisture!
- \* DO NOT clean with liquid detergent or alcohol based cleaners as this may affect the clarity of the LCD over time.
- \* Clean only with a soft lint free dry cloth.
- \* Care should be exercised when using the carry strap as this can present a choking hazard, and should only be used when slipping or falling is not a possibility.
- \* DO NOT disassemble your meter or interfere with the internal components; there are no user serviceable parts inside this action will invalidate your warranty and there is a potential risk of electric shock.

**If this equipment is used in a manner not specified by the manufacturer, the protection provided by this equipment may be impaired.**



Only use the battery pack, mains lead and in car charger provided with your unit, as using other types may result in damage to your unit, which will invalidate your warranty and potentially cause electric shock. Replacement battery packs and accessories are available directly from Horizon Global Electronics Ltd.

Should repair or service be required please contact us directly at Horizon Global Electronics Ltd by calling +44 (0)1279 417 005 or via email through our web site at [www.horizonhge.com/contact.html](http://www.horizonhge.com/contact.html)

## Lithium Polymer Battery Care and Usage.

This meter features the latest developments in Li-Po battery technology. Li-Po batteries have excellent capacity and are lightweight. DO NOT expose the supplied battery to impact, moisture, or short the connecting terminals; as these actions can result in sever hazards or irreparable damage to your meter.

## Instructions of disposal of WEEE by users in the European Union



This product must not be disposed of with other waste. Instead, it is the user's responsibility to dispose of their waste equipment by handing it over to a designated collections point for the recycling of waste electrical and electronic equipment. The separate collection and recycling of your waste equipment at the time of disposal will help to conserve natural resources and ensure that it is recycled in a manner that protects human health and the environment. For more information about where you can drop off your waste equipment for recycling, please contact your local city office, your household waste disposal service or where you purchased the product.

# Your Meter

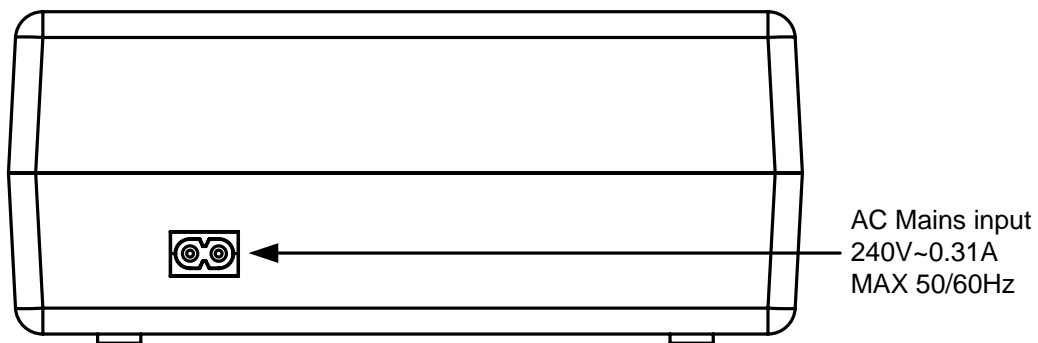
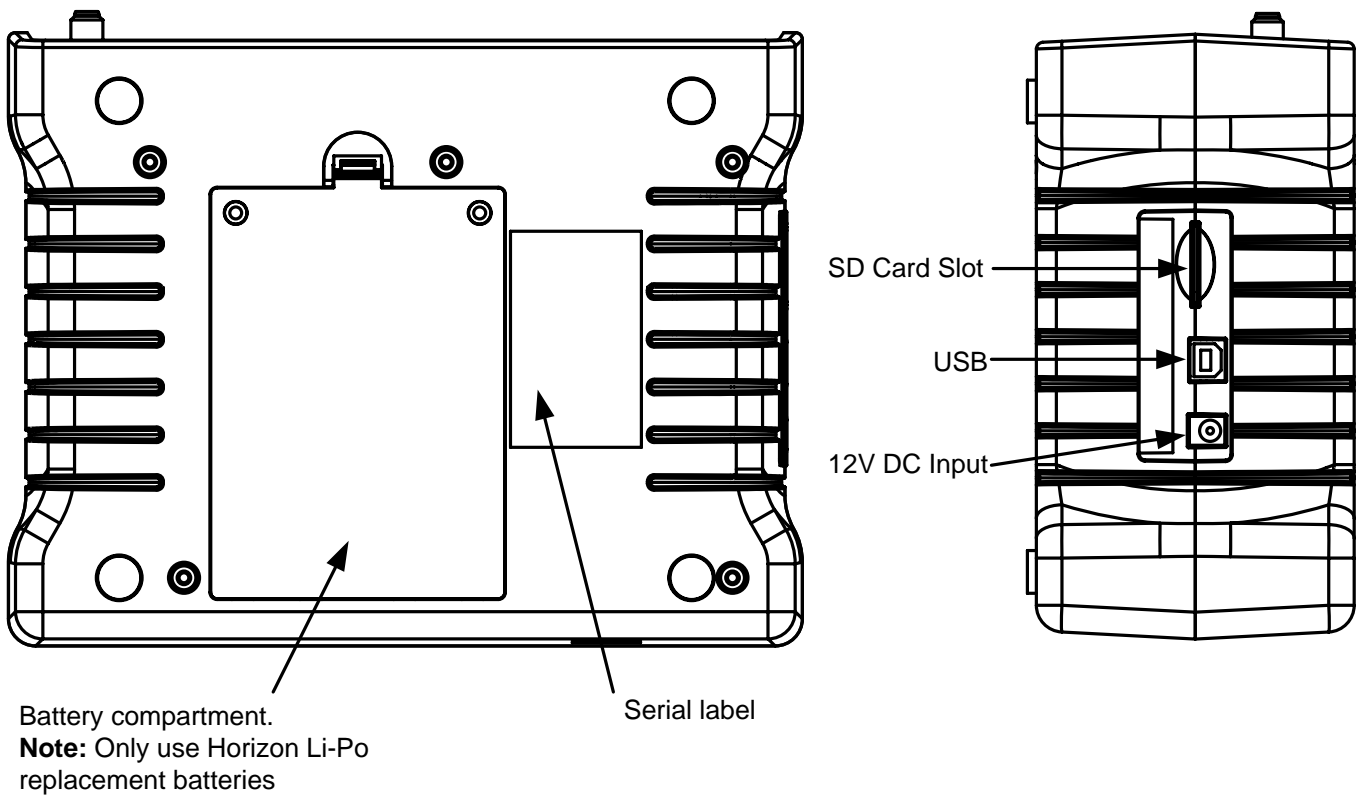
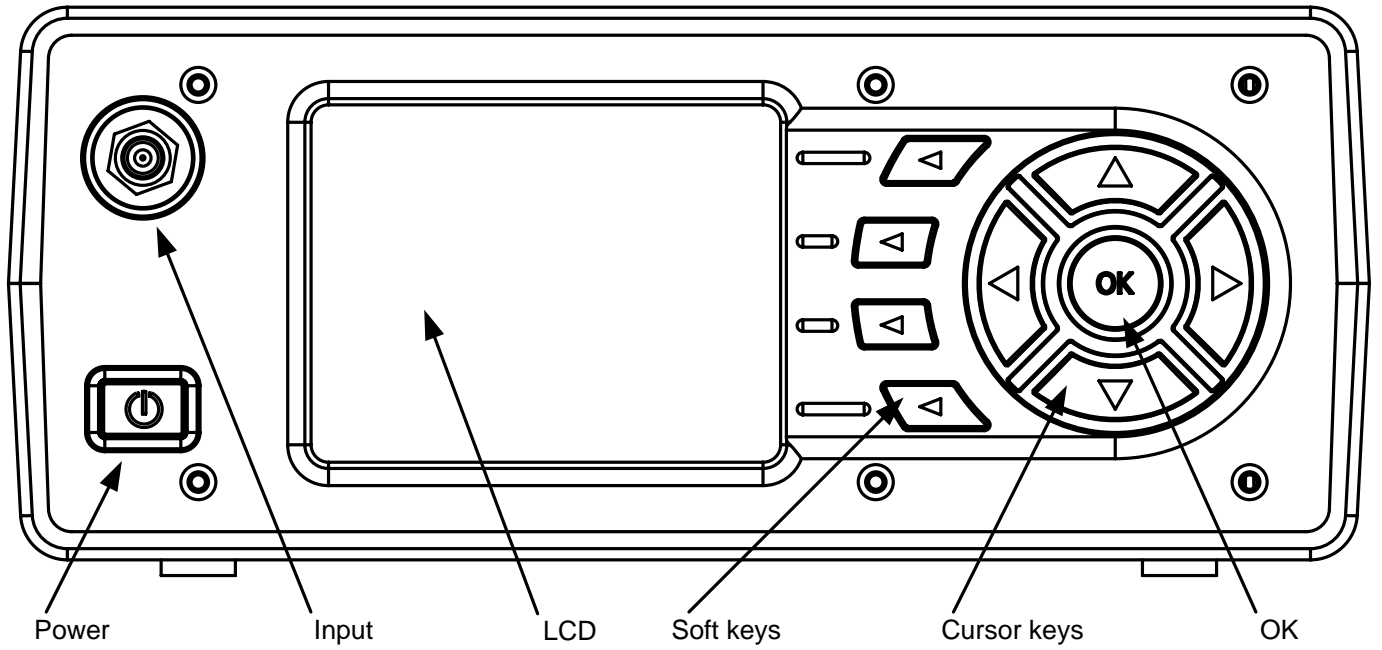

## Accessories

---

Your HD-STM is supplied with the items shown below. Please check that you have all of the following items. If any are missing please contact your supplier.



**Only manufacturer's replacement parts should be used, otherwise safety of your meter may be impaired**



**DC Car Charger Lead  
Fitted with 2 Amp Fuse**



**USB Lead**



**AC Mains Charger Lead**



**Li-Po Battery Pack**

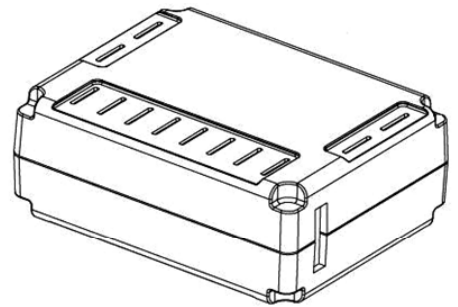

**Note:** The correct mains lead for your country will be supplied.

**CD Rom** (contains user guide and software)

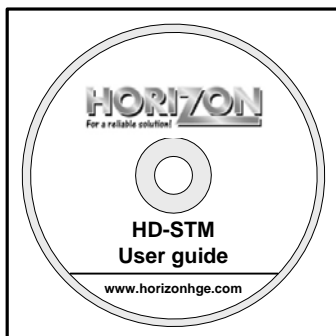

**SD Card** (fitted)



# Battery Charging

On receiving your meter you will need to charge the batteries for at least 8 Hours prior to the first use. It is recommended to charge your meter overnight prior to the next working day. An in car charger is also provided for topping up the battery if necessary en route to the next installation.

The figure of 8 mains lead supplied connects here for mains charging. The internal charger will auto detect the mains supply voltage and is designed for world wide usage.

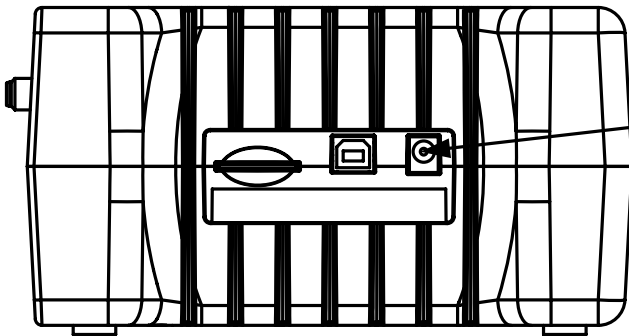
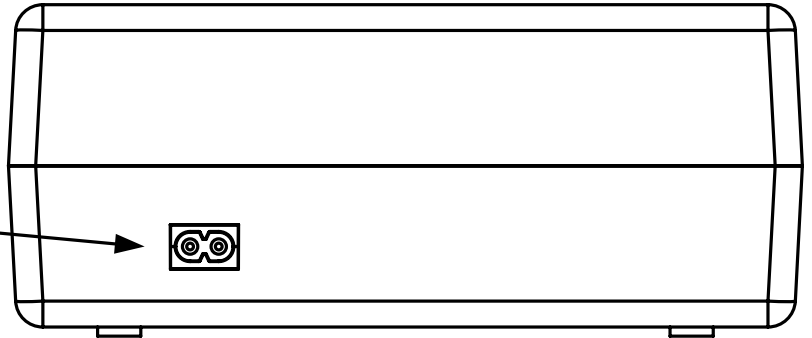

The supplied in car charger can be connected here for top up charging from your vehicle. This input is designed for 12V DC input only.

**Note:** On some vehicles the aux socket is switched off unless the vehicle engine is running.

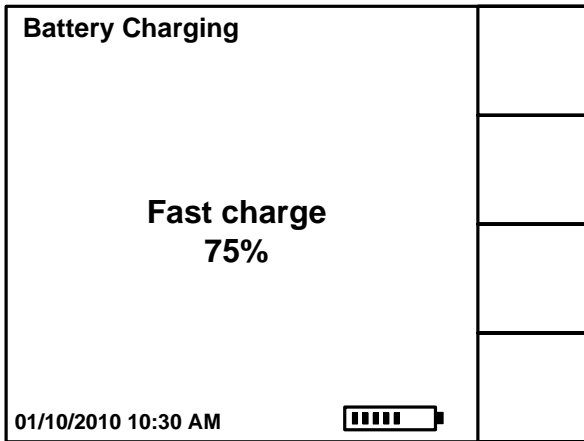

During charging the LCD back light will remain off and charge state information illustrated on the left will appear. The time and date will also appear on the display. A small animated battery icon will also appear showing that charging is taking place.

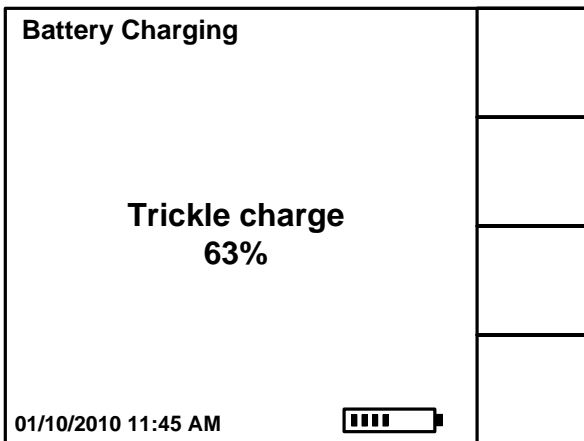

If the meter has been left on charge for an extended period of time it will enter a trickle charge state.

# Initial Start Up

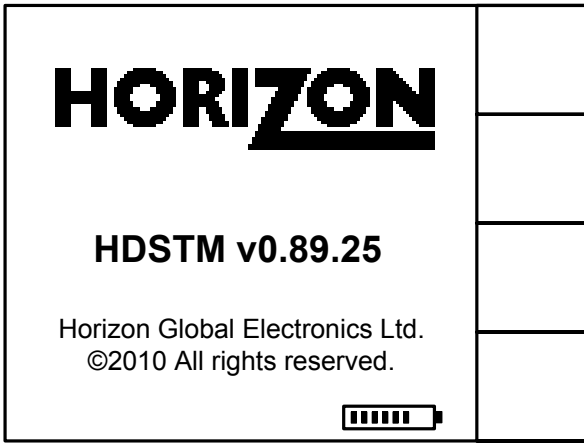

When you first receive your HD-STM meter and power it up for the first time (after the initial charge) the animated Horizon logo will appear and the version of your meter will be displayed.

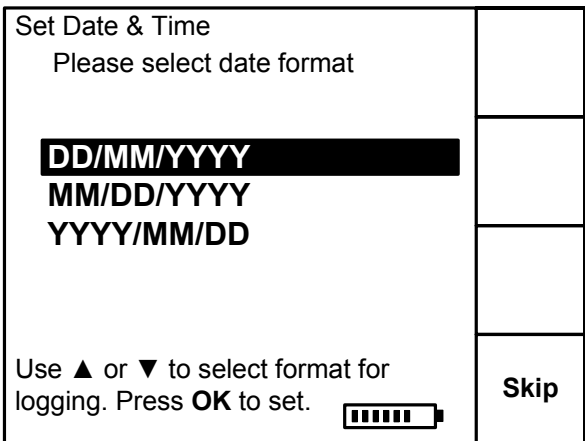

On the next screen you can select the format for the date. In the example on the left Day / Month / Year has been highlighted. Use the up and down cursor keys to make your selection and press "OK" to continue.

**Note:** This date format will be applied to any measurements logged on your meter.

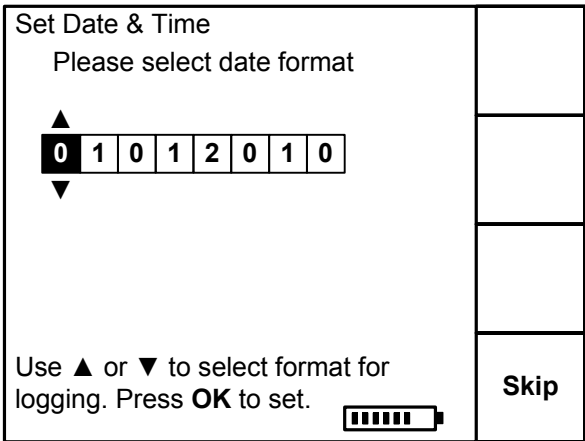

You will be prompted to enter date and time (for log entry purposes). If you wish this option can be skipped by pressing the function button in the bottom right of the display marked "Skip". The date and time can also be set from the set up menu later. Pressing "OK" will take you on to the next step.

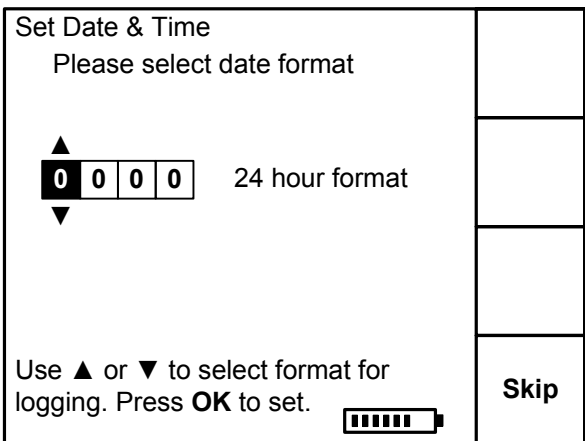

Enter the time in a 24 hour format. On the next screen you will be able to select 24 hour clock or 12 hour clock with AM and PM display.

**Note:** Your meter features guide text. This is where the bottom two lines of the display will prompt you as to what action to take next or what additional features are available in the mode you have chosen to operate in.

Set Date & Time Please set display format  <div style="background-color: black; color: white; padding: 2px;"><b>24 Hour Clock</b></div> <b>12 Hour Clock AM/PM</b>  Use ▲ or ▼ to select format for logging. Press <b>OK</b> to set. 	<b>Skip</b>
---	-------------

On the next screen you can select the time format as 12 hour AM / PM or 24 Hour clock. Use the up and down keys to select and press “**OK**” to set.

Current Date & Time Set  <div style="text-align: center; font-size: 1.2em;"><b>01/10/2010 09:15</b></div>  Press OK to set or Back to change. 	<b>Back</b>
---	-------------

Once the time format has been selected you can then proceed to set the time using the cursor keys, and press the “**OK**” button to confirm.

Now that the date and time has been set you can choose to set this as the current date and time by pressing the “**OK**” button (this will also start the clock from the moment “**OK**” is pressed). Alternatively you can use the “**Back**” soft key to make any changes required. Once the clock is set you will not need to do this operation again unless you which to change the date and time by using the Setup menu.

Please select operating mode  <div style="background-color: black; color: white; padding: 2px;"><b>Satellite (DVB-S/S2)</b></div> <b>Terrestrial (DVB-T)</b> <b>SD Card Options</b> <b>Setup</b>  Use the ▲ or ▼ and OK to select or use the function keys on the right.  01/10/2010 11:50 AM 	<b>SAT</b>
	<b>TER</b>
	<b>Setup</b>

Once the clock is set you are then presented with the operating mode option screen where you can choose from Satellite or Terrestrial. The guide text at the bottom of the screen will inform you of what options are available and how to access them.

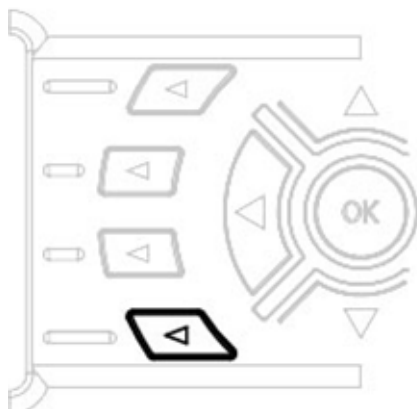

**Tip:** From either satellite or terrestrial mode you can return to the operating mode selection screen by pressing and holding the bottom soft key.

# Setup

Setup Mode		
<b>Audible Click</b>	<b>On</b>	
LCD Backlight	1 Minute	
LCD Brightness	10	
LCD Contrast	15	
Sleep Timer	6 Minutes	
Language	English	
Use the ◀ or ▶ key to set <b>On</b> or <b>Off</b> Press the key ▼ for more options		<b>Back</b>
01/10/2010 10:30 AM 		

The Set up function allows you to customise how your meter operates and can be accessed from the Set up soft key on start up or from the main options menu. Shown here are the first six basic options where you can enable or disable the audible click or the LCD backlight. The LCD Brightness can be adjusted along with the LCD contrast. The Sleep timer and system Language can be set to your preferences also.

The cursor keys will enable you to change these values and the guide text at the bottom of the screen will also advise you as to the options of each setting.

Setup Mode		
Set date & time		
Show RF as	dBuV	
Show Carrier as	C/N	
LNB Volts	13/18V	
Factory Reset	Default All	
<b>Terrestrial Mode</b>	<b>DVB-T</b>	
Use the ◀ or ▶ key to select Press the key ▼ for more options		<b>Back</b>
01/10/2010 10:30 AM 		

Scrolling further down reveals more options to select from. The RF measurement can be displayed as dBuV or Linear (a simplified scale). The carrier measurement method can be shown as C/N (Carrier to Noise) or MER (Modulation Error Rate) both expressed in dB. The LNB Voltage is set for 13/18 volt operation and can also be disabled (Zero). The Factory Reset will reset the meter to default setup but will have no effect on downloaded settings for satellite and terrestrial. The Terrestrial Mode defaults to DVB-T but other digital terrestrial formats are available for the region of use. Selecting Undefined for Terrestrial Mode prevent access to the terrestrial mode.

Setup Mode		
Show RF as	dBuV	
Show Carrier as	C/N	
LNB Volts	13/18V	
Factory Reset	Default All	
Terrestrial Mode	DVB-T	
<b>SVN-1310</b>		
Press the key ▲ for more options		<b>Back</b>
01/10/2010 10:30 AM 		

The bottom function of the Setup Mode is for Horizon use only to provide firmware version information and has no other function.

Once you have made your selections for the meter setup press the Back button to save these values. You will then be returned to the Select Operating Mode screen.





# Satellite

# Satellite Finding





Please select operating mode  <b>Satellite (DVB-S/S2)</b> Terrestrial (DVB-T) SD Card Options Setup  Use the ▲ or ▼ and OK to select or use the function keys on the right.  01/10/2010 10:30 AM 	SAT
	TER
	Setup

After you have switched your meter on you can select from Satellite or Terrestrial this can be selected by using the cursor keys and the "OK" button or directly from the soft keys.

**Note:** The guide text will inform you as to the options available.

<b>V Astra 2A Hi 28E</b> <b>S</b>  <b>73 dBuV</b>  <b>Searching</b>  Press ◀ or ▶ to select satellites Hold More to exit  01/10/2010 10:30 AM 	List
	Spect
	Custom
	More

Once you have selected Satellite from the options from the operating mode choices you are presented with a satellite selection displayed at the top of the screen and an indication of RF level in dBuV. In this example we are in an unlocked condition. You can cycle through the list of available satellites by using the left or right cursor keys. During the alignment process the RF level will increase and decrease as you pass various satellites. On identifying the chosen satellite the meter display will change as shown in the next example.

<b>V Astra 2A Hi 28E</b> <b>S</b>  <b>73 dBuV</b> <b>C</b>  <b>12.5 dB</b> <b>Q</b>  <b>3.30E-7</b> <b>V</b>  <b>0.00E-8</b>  <b>Found</b>  Press ◀ or ▶ to select satellites Hold More to exit  01/10/2010 10:30 AM 	Log
	Spect
	Const
	More

In the example on the left the Satellite Finding mode is shown in a locked condition, and **Found** is indicated at the bottom of the display.

- S** Signal Level in dBuV
- C** Carrier to Noise in dB
- Q** Pre BER (Bit Error Rate before correction)
- V** Post BER (Bit Error Rate after correction)

In all instances we are looking to get the bar graphs as high as possible. Maximise the performance of the antenna by using fine adjustments while pointing and keeping an eye on levels while tightening up the antenna fixings.

<b>Satellite List</b>  Please select Satellite  <b>V Astra 2A High 28.2E</b> H Astra 2A High 28.2E V Astra 2D Low 28.2E H Astra 2D Low 28.2E V Astra 2A S2 28.2E  Press ▲ or ▼ for the required Satellite and press OK to select.  01/10/2010 10:30 AM 	
	Back

**Note:** For rapid access to the satellite selections available the Satellite List where you can scroll quickly through the list of satellites and press "OK" to select.

Pressing **Back** takes you back to the last selected satellite in the satellite finding mode.

# Satellite Spectrum Display

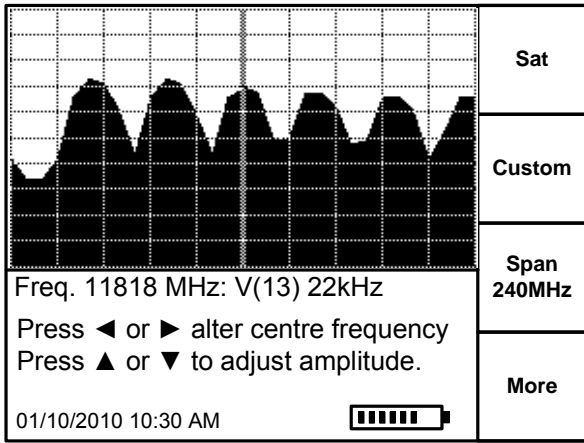

Pressing **SAT** will return you to the Satellite Finding mode.

Pressing **Custom** takes you to the Custom Carrier Mode (covered later).

Pressing **Span** cycles through the available spans of 60, 120, 240, 480, 960 and 1200MHz

Pressing **More** will show you the additional functions available from the Spectrum mode.

From the satellite mode you can select the Spectrum Display by pressing the **Spect** soft key indicated on the right hand side of the display and you will be presented with a spectrum display similar to that shown above. For simplicity the carrier used for identification will be the centre frequency (as indicated by the vertical centre line on the spectrum display). You can adjust the centre frequency by using the left or right cursor keys and the frequency information is displayed underneath the spectrum. You can also adjust the amplitude with the up an down cursor keys so that carriers and noise floor can be seen easily.

**Note:** You can return to the satellite finding mode at any time by pressing the **Sat** soft key.

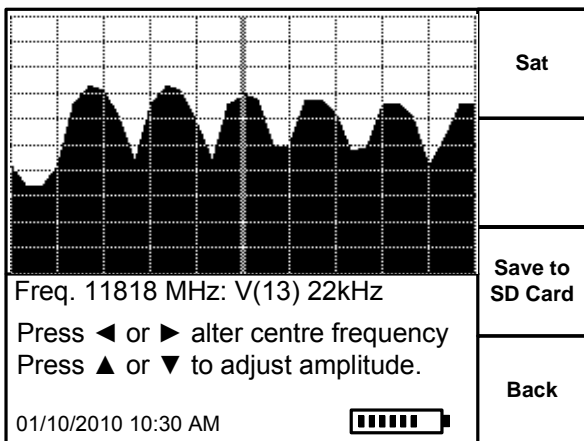

Pressing **SAT** will return you to the Satellite Finding Mode

Pressing **Save to SD Card** will enable you to grab a screen shot of the spectrum display saving it as a .bmp (bit map) file.

Pressing **Back** will return you to the previous spectrum options (as above).

The guide text at the bottom of the display here is showing you how to return to Sat Finding mode or go back to the Spectrum display.

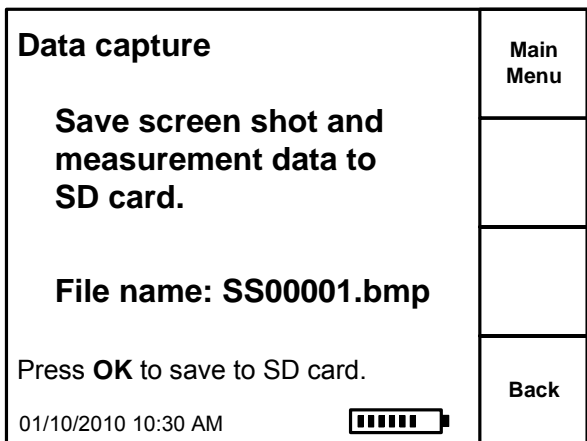

If you choose to save the spectrum display to the SD card the whole screen is captured as a .bmp file. Once the image has been saved you will be returned to the spectrum display.

Satellite spectrum data capture is stored as incremental files prefixed SS and then the file number. The image is also time and date stamped.

# Satellite Constellation

The HD-STM can also display a satellite constellation diagram QPSK and 8PSK format modulation is supported.

**Note:** The constellation will only operate correctly when locked on to a digital carrier in DVB QPSK / 8PSK modulation.



By selecting **SAT** you can return to the satellite finding mode (on the last selection made).

Pressing **Save to SD Card** will enable the user to grab a screen shot of the spectrum with details of the carrier if a locked condition is possible as a .bmp file.

Pressing **Back** will also return you back to the Satellite Finding Mode.

The example above shows the constellation diagram of a DVB QPSK service. On the right hand side of the display the receive parameters are also shown.

In the constellation mode it is also possible to save a screen shot to your SD card for the purpose of producing reports and records of installation results.

The constellation diagram can be a very useful tool for fault finding and diagnosis, as it can be used to find a point where noise has been introduced into a system where it may not be present elsewhere.

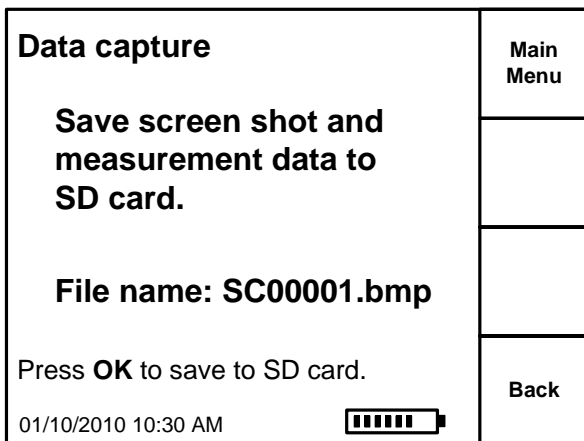

If you choose to save the constellation display to the SD card the whole screen is captured as a .bmp file. Once the image has been saved you will be returned to the constellation display.

Satellite constellation data capture is stored as incremental files prefixed SC and then the file number. The image is also time and date stamped.

## Custom carrier

The custom carrier mode is a very useful feature for the direct measurement of a desired satellite service, and also offers the flexibility of direct tuning no matter what type of satellite system is being installed. The custom carrier feature can be especially useful for VSAT installations.

<b>Custom Carrier</b> <b>Save Custom Carrier</b> <b>Slot 1: Empty</b> <b>Slot 2: Empty</b> <b>Slot 3: Empty</b> <b>Slot 4: Empty</b> <b>Slot 5: Empty</b> <b>Slot 6: Empty</b> Press ▲ or ▼ to choose a slot Press OK to select and name. 01/10/2010 10:30 AM 	<b>Sat</b>  <b>Delete</b>  <b>Back</b>
---	--

Pressing the **Sat** button will return you the the last satellite selection that you made.

The **Delete** button can be used to delete any previously stored custom carriers.

Pressing the **Back** button will also return you the the last satellite selection that you made.



<b>Custom Carrier</b> <b>Save Custom Carrier</b>  <b>Slot 1:</b> <table border="1" style="margin: 10px auto;"> <tr> <td>T</td><td>E</td><td>S</td><td>T</td><td>1</td><td></td><td></td><td></td><td></td> </tr> </table> Press ▲▼◀▶ to enter name Press OK to store. 01/10/2010 10:30 AM 	T	E	S	T	1					<b>Sat</b>  <b>Letter</b>  <b>Number or Symbol</b>  <b>Back</b>
T	E	S	T	1						

Pressing the **Sat** button will return you the the last satellite selection that you made.

Press the **Letter** button to enter letters from A to Z.

Press the **Number or Symbol** button to enter numbers or maths symbols.

Pressing the **Back** button will return you the previous screen illustrated above.

<b>Test 1</b> <b>10700MHz</b>  <b>C</b>  <b>Searching</b> <b>LNB L.O. 9.75GHz</b> <b>Frequency 10700MHz</b> <b>Format DVB-S Q</b> Press ◀ or ▶ to select L.O. Press ▼ to continue. 01/10/2010 10:30 AM 	<b>SAT</b>  <b>Save</b>  <b>Back</b>
--	--

The first option highlighted enables you to select the local oscillator required by using the left or right cursor keys, the table below illustrates the local oscillator selections that are available.

Once you have selected your local oscillator press the down cursor key to edit the frequency.

Ku-Band	Ka-Band	C-Band	L-Band
9.75 GHz	18.25 GHz	5.15 GHz	0 GHz
10.6 GHz +22KHz	18.75 GHz	5.76 GHz	
10.0 GHz	19.25 GHz	5.95 GHz	
10.5 GHz	19.75 GHz		
10.25 GHz	21.0 GHz		
10.7 GHz			
10.7 GHz +22KHz			
10.75 GHz			
10.75 GHz + 22KHz			
11.25 GHz			
11.25 GHz + 22KHz			
11.3 GHz			
11.3 GHz + 22KHz			

Continued...

Test 1    10700MHz C Searching Frequency <b>1 0 7 0 0</b> MHz Press OK to change setting Press ▲ or ▼ for more options. 01/10/2010 10:30 AM	Sat   Save  Back
---	---------------------------------

Each digit is selected by using the up and down cursor keys to rotate the numbers from 0 to 9 and then pressing the right arrow cursor key to select the next number. If you need to correct a number the left cursor key can be used. Once you have set the desired frequency press the "OK" button to move on.

**Tip:** If you are entering a C-Band frequency please use a leading zero, for example 03842.

**Note:** If the entered frequency is out of range for the previously selected LNB Local Oscillator then a notification will appear.

Test 1    10700MHz C Searching LNB L.O.    9.75GHz Frequency    10700MHz Format        DVB-S Q Press ◀ or ▶ to change setting. Press ▼ or ▲ for more options. 01/10/2010 10:30 AM	SAT   Save  Back
---	---------------------------------

The HD-STM can acquire a lock on DVB QPSK and DVB 8PSK carriers and this is defined here. Most carriers are DVB-S QPSK.

The following options for this selection are available.

- DVB-S Q            (QPSK)            default
- DVB-S 8            (8PSK)
- DVB-S2 Q          (QPSK)
- DVB-S2 8          (8PSK)

Use the left or right cursor keys to change this value if required and then the down cursor key to select Symbol Rate.

Test 1    10700MHz C Searching Frequency    10700MHz Format        DVB-S Q Symbol Rate   27500 Press OK to change setting. Press ▲ or ▼ for more options. 01/10/2010 10:30 AM	SAT   Save  Back
---	---------------------------------



Press "OK" to enter a symbol rate.

**Note:** the default value is 27500 but any symbol rate from 1000 to 45000 can be entered.

Test 1    10700MHz C Searching Symbol rate <b>2 7 5 0 0</b> Press OK to change setting Press ▲ or ▼ for more options. 01/10/2010 10:30 AM	SAT   Save  Back
---	---------------------------------

The method of selecting numbers for the symbol rate is the same as entering the frequency earlier uses the up and down cursor keys to change the number value and the right arrow button to step on to the next number. If a correction needs to be made you can use the left cursor key.

**Note:** To enter a symbol rate of less than 10000 please ensure that the first number is a zero, for example 05362.



Test 1    10700MHz <b>C</b>  Searching Format        DVB-S Q Symbol rate   27500 <b>FEC            1/2</b>	SAT
Press ◀ or ▶ to change setting. Press ▼ or ▲ for more options.	Save
01/10/2010 10:30 AM 	Back

Depending on the DVB-S format selected the following FEC options are available to select from by using the left or right cursor keys to cycle through them.

FEC's available in **DVB-S** QPSK & 8PSK  
 1/2, 2/3, 3/4, 5/6, 7/8

FEC's available in **DVB-S2** QPSK & 8PSK  
 1/4, 1/3, 2/5, 1/2, 3/5, 2/3, 3/4, 4/5, 5/6, 8/9, 9/10

Once you have selected your FEC use the down cursor key to move on to Polarity.



Test 1    10700MHz <b>C</b>  Searching Symbol rate   27500 FEC            3/4 <b>Polarity       0 Volts</b>	SAT
Press ◀ or ▶ to change setting. Press ▼ or ▲ for more options.	Save
01/10/2010 10:30 AM 	Back

The following LNB supply voltages can be selected.

V 13 Volts (Vertical or Right Hand Circular)  
 H 18 Volts (Horizontal or Left Hand Circular)  
 0 Volts (no voltage applied)



The zero volts option can be used where DC is already supplied (by a power inserter) or where a splitter is used.

Once the Polarity has been selected use the down cursor key to select the next option IQ Swap.

Test 1    10700MHz <b>C</b>  Searching FEC            3/4 Polarity       H 18 Volts <b>IQ Swap       Normal</b>	SAT
Press ◀ or ▶ to change setting. Press ▼ or ▲ for more options.	Save
01/10/2010 10:30 AM 	Back

The IQ Swap function is not used very often; usually it is set to **Normal**, however it is quite common to use IQ Swap on C-Band services.

**Tip:** Should you fail to acquire a lock once you have set all the parameters try IQ Swap.

Test 1    10700MHz <b>C</b>  14.7 dB <b>Q</b>  3.30E-7 FEC            3/4 Polarity       V 13 Volts <b>IQ Swap       Normal</b>	SAT
Press ◀ or ▶ to change setting. Press ▲ or ▼ for more options.	Save
01/10/2010 10:30 AM 	Back

Once a lock is acquired found will appear and the Q (Pre-BER) display will also appear. You can save your custom carrier by pressing the **Save** button.

## DiSEqC (Switch)

<p><b>DiSEqC</b></p> <p style="text-align: center;"><b>Switch or Motor</b></p> <p>Use the function buttons to select the DiSEqC required.</p> <p>01/10/2010 10:30 AM </p>	SAT
	Switch
	Motor
	Back

The HD-STM features DiSEqC for controlling motors and operating switches.

From the DiSEqC menu you can select Switch or Motor. Pressing **SAT** or **Back** here will take you back to the last satellite selected in the Satellite Finding Mode.

<p><b>DiSEqC Switch</b></p> <p style="text-align: center;"><b>Please select</b></p> <p><b>4 Position Switch</b></p> <p><b>Options</b></p> <p><b>Dual Horn</b></p> <p><b>SMATV Switch</b></p> <p>Press ▲ or ▼ for required DiSEqC and press <b>OK</b> to select</p> <p>01/10/2010 10:30 AM </p>	SAT
	Back

The 4 Position Switch selection enables you to operate DiSEqC switches up with up to 4 ports.

The Options selection enables you to send Tone Burst commands (A or B).

The Dual Horn option is for use with dual feed LNB assemblies enabling you to select the band and polarisation available individually.

The SMATV switch option is for use with systems with up to 16 inputs. Pressing **Back** will return you to the DiSEqC menu.



<p><b>DiSEqC 4 Position Switch</b></p> <p style="text-align: center;"><b>Please select</b></p> <p><b>DiSEqC A</b></p> <p><b>DiSEqC B</b></p> <p><b>DiSEqC C</b></p> <p><b>DiSEqC D</b></p> <p>Press ▲ or ▼ for required DiSEqC and press <b>OK</b> to select</p> <p>01/10/2010 10:30 AM</p>	SAT
	Back

In this example we have chosen DiSEqC 4 Position switch, and from here we can select A, B, C or D (Ports 1 to 4). Pressing **Back** will return you to the menu above.

<p><b>DiSEqC 4 Position Switch</b></p> <p style="text-align: center;"><b>DiSEqC A</b></p> <p style="text-align: center;"><b>Command Sent</b></p> <p>Returning to Satellite mode.</p> <p>01/10/2010 10:30 AM</p>	



After a short delay (of approximately 4 seconds) you will be returned to Satellite Finding mode with the DiSEqC command applied.

## DiSEqC (Motor Control)



<b>DiSEqC Motor</b> <b>V Astra 2A Hi 28.2E</b> <b>S</b>  <b>67 dBuV</b> <b>In Motion</b> ▶▶▶▶ <b>Searching</b> Press and hold ◀ or ▶ to move and <b>OK</b> to store. 01/10/2010 10:30 AM 	<b>SAT</b> <b>Zero Pos.</b> <b>Back</b>
---	---

The DiSEqC motor control will enable you to check the alignment of DiSEqC motorised systems. To operate your DiSEqC motor ensure that your connections to the motor are made first. Pressing the right cursor key will move the antenna in one direction and pressing the left cursor key will move the antenna in the other direction. Releasing the cursor key will stop the motor.

The “**Zero Pos.**” option on the soft key will enable you to return the DiSEqC motor to its **Zero Position**.

<b>DiSEqC Motor</b> <b>V Astra 2A High Band 28.2E</b> <b>S</b>  <b>67 dBuV</b> <b>Q</b>  <b>2.02E-4</b> <b>Stopped</b> ■ <b>Found</b> Press ◀ or ▶ cursor keys to move the dish. 01/10/2010 10:30 AM 	<b>SAT</b> <b>Zero Pos.</b> <b>Back</b>
---	---

In the example screen shot on the left we can see the **V Astra 2A Hi 28.2E** selection has acquired a lock (Found). The DiSEqC motor can be jogged by tapping the cursor keys to improve the signal levels.

<b>DiSEqC Motor</b> <b>V Astra 2A High Band 28.2E</b> <b>S</b>  <b>67 dBuV</b> <b>Returning motor to Zero</b> <b>Searching</b> Press ◀ or ▶ to interrupt motion. 01/10/2010 10:30 AM 	<b>SAT</b> <b>Zero Pos.</b> <b>Back</b>
---	---

Selecting **SAT** will return you user to the satellite finding mode with the last satellite chosen selected.

Selecting **BACK** will also return you user to the satellite finding mode with the last satellite chosen selected.

**Note:** The DiSEqC motor function will drain your battery faster than your meter in normal use. The return to zero position (Zero Pos.) function can be interrupted at any time by pressing the right or left cursor key once.

# LNB & Cable Test

<p><b>LNB &amp; Satellite Cable Test</b></p> <p>This function tests for an open or short circuit in the Satellite cable and checks for RF returned from the LNB.</p> <p>Press <b>OK</b> to start the test.</p> <p>01/10/2010 10:30 AM </p>	<p>SAT</p> <p>Back</p>
---	------------------------

The HD-STM features a LNB and cable test for satellite installations. Pressing the **Sat** or **Back** soft key will return you to the last selected satellite.

**How this works:** The Test function checks for possible Cable or LNB fault conditions and provides a indicative result as a guide only. The RF Level is checked without power and then LNB power is applied, if the RF level increases then the LNB is OK. If the LNB current is too low or too high then then LNB or cable has a Fault condition.

<p><b>LNB &amp; Satellite Cable Test</b></p> <p><b>LNB &amp; Cable: OK</b></p> <p>Test complete.</p> <p>01/10/2010 10:30 AM </p>	<p>SAT</p> <p>Back</p>
---	------------------------

After a few seconds the LNB and Satellite Cable Test would have completed and the results will be displayed in the centre of the screen as illustrated on the left.

<p><b>LNB &amp; Satellite Cable Test</b></p> <p><b>LNB &amp; Cable: FAULT</b></p> <p>Test complete.</p> <p>01/10/2010 10:30 AM </p>	<p>SAT</p> <p>Back</p>
--	------------------------

If a Fault condition is reported back this indicates there is no communication between your meter and the LNB and examination of cable and connections is recommended.

<p><b>LNB &amp; Satellite Cable Test</b></p> <p><b>LNB: FAULT</b></p> <p>Test complete.</p> <p>01/10/2010 10:30 AM </p>	<p>SAT</p> <p>Back</p>
--	------------------------

In an LNB Fault condition it is most likely that the cable is correctly passing voltage to operate the LNB but there is no RF return from the LNB indicating that the LNB could be at fault.





# Terrestrial

# Terrestrial Finding





<p>Please select operating mode</p> <p><b>Satellite (DVB-S/S2)</b></p> <p><b>Terrestrial (DVB-T)</b></p> <p><b>SD Card Options</b></p> <p><b>Setup</b></p> <p>Use the ▲ or ▼ and OK to select or use the function keys on the right.</p> <p>01/10/2010 10:30 AM </p>	SAT
	TER
	Setup

On selecting Terrestrial from the start up screen illustrated on the left you will be taken to the UHF Step Through screen or the last transmitter selected.

<p><b>UHF Step Ch. 23</b></p> <p>S  52 dBuV</p> <p>C  33 dB</p> <p>Searching</p> <p>Press ◀ or ▶ to select the next UHF channel.</p> <p>01/10/2010 10:30 AM </p>	TERR Menu
	MHP 0V
	Scan
	More

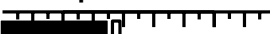
In this screen shot on the left we can see that on channel 23 there is a high RF and carrier to noise level this indicates the presence of an Analogue service.





**Note:** If a transmitter has been selected the Analogue measurements are shown in full.

<p><b>UHF Step Ch. 25</b></p> <p>S  46 dBuV</p> <p>C  22 dB</p> <p>Q  6.30E-3</p> <p>V  3.00E-8</p> <p><b>DVB-T 506MHz **** Pass</b></p> <p>Press ◀ or ▶ to select the next UHF channel.</p> <p>01/10/2010 10:30 AM </p>	TERR Menu
	MHP 0V
	Scan
	More

In this example on the left we have acquire a lock on a DVB-T mux on channel 25 at the frequency of 506MHz.

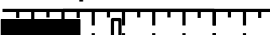
The RF level is indicated in dBuV on the S bar, the carrier to noise is indicated on the C bar the Pre BER is shown on the Q bar (errors before correction) and Post BER is shown on the V bar, BER values are also shown numerically.

In Step Through UHF you can select channel numbers by using the left or right cursor keys.

<p><b>UHF Step Ch. 25</b></p> <p>S  39 dBuV</p> <p>C  20 dB</p> <p>Q  1.30E-3</p> <p>V  4.10E-7</p> <p><b>DVB-T 506MHz *** Marginal</b></p> <p>Press ◀ or ▶ to select the next UHF channel.</p> <p>01/10/2010 10:30 AM </p>	TERR Menu
	MHP 0V
	Scan
	More

As the antenna is moved to improve the signal you will see the levels rise and fall, to further assist with alignment the peak hold bars will show how high the signal was previously during adjustment making it easier to return to the peak level.

# Terrestrial Menu

<p><b>Terrestrial Menu</b> Please select an option</p> <p><b>Post Code</b></p> <p><b>Region</b></p> <p><b>Step through UHF</b></p> <p><b>Step through VHF</b></p> <p>Press ▼ for the required option and press <b>OK</b> to select.</p> <p>01/10/2010 10:30 AM </p>	<p>Main Menu</p> <p>Back</p>
--	------------------------------





On selecting the **TERR Menu** function you can choose from selecting transmitter by **Post Code**, **Region**, **Step through UHF** or **Step through VHF** by using the cursor keys to choose your preference and the **OK** button to select.

<p><b>Terrestrial Post Code Entry</b> Please enter the first half of the installation site post code.</p> <p><b>A</b> <input type="text"/> <input type="text"/> <input type="text"/></p> <p>Press ▲ or ▼ to select and ► for next character.</p> <p>01/10/2010 10:30 AM </p>	<p>TER Menu</p> <p>Back</p>
---	-----------------------------

For post code look up only the first 3 or 4 characters need to be entered using the cursor keys. On pressing **OK** the nearest transmitters to your location will be displayed in a list for you to pick from.

<p><b>Transmitter List for Post code</b> Please select a transmitter</p> <p><b>+Hemel Hempstead</b></p> <p><b>+Crystal Palace</b></p> <p><b>+Sandy Heath</b></p> <p><b>+Sudbury</b></p> <p>Press ▲ or ▼ for the required Transmitter and <b>OK</b> to select.</p> <p>01/10/2010 10:30 AM </p>	<p>TER Menu</p> <p>Back</p>
--	-----------------------------

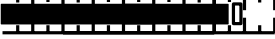
In the example on the left a post code for the Harlow Essex region in the UK was entered and a list of transmitters was generated from the main power transmitters that cover that region.

<p><b>+Crystal Palace Ch. 22</b></p> <p><b>S</b>  <b>46 dBuV</b></p> <p><b>C</b>  <b>22 dB</b></p> <p><b>Q</b>  <b>6.30E-3</b></p> <p><b>V</b>  <b>3.00E-8</b></p> <p><b>DVB-T 482MHz **** Pass</b></p> <p>Press ◀ or ▶ to select the next UHF channel.</p> <p>01/10/2010 10:30 AM </p>	<p>TERR Menu</p> <p>MHP 0V</p> <p>Scan</p> <p>More</p>
--	--

With the transmitter selected we can step through the available UHF analogue and digital services by using the left and right cursor keys.

# Terrestrial Menu

<b>Terrestrial Menu</b> Please select an option  <b>Post Code</b> <b>Region</b> <b>Step through UHF</b> <b>Step through VHF</b>  Press ▼ for the required option and press OK to select.  01/10/2010 10:30 AM 	Main Menu          Back
---	---

To select a transmitter by region highlight the **Region** option and press **OK**.





<b>Transmitter regions UK</b> Please select a region <b>Anglia</b> <b>Boarder</b> <b>Central</b> <b>Channel Islands</b> <b>Granada</b> <b>London</b>  Press ▲ or ▼ for the required region and OK to select.  01/10/2010 10:30 AM 	TER Menu          Back
--	--

Highlight the region you require and press the **OK** button.

<b>Transmitter List London</b> Please select a transmitter  <b>+Hemel Hempstead</b> <b>+Crystal Palace</b> <b>+Sandy Heath</b> <b>+Sudbury</b>  Press ▲ or ▼ for the required Transmitter and OK to select.  01/10/2010 10:30 AM 	TER Menu          Back
--	--

In this example we selected region **London** and transmitter **+Crystal Palace**.

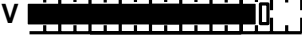
**Note:** The “+” symbol indicates that this is a main power transmitter.

<b>+Crystal Palace Ch. 22</b> S  46 dBuV C  22 dB Q  6.30E-3 V  3.00E-8  <b>DVB-T 482MHz **** Pass</b>  Press ◀ or ▶ to select the next UHF channel.  01/10/2010 10:30 AM 	TERR Menu   MHP 0V  Scan  More
---	---

The chosen transmitter will show with the first active digital carrier shown, or the last one selected if previously used. From here you can use the cursor keys to step through the available carriers (Digital and Analogue) from the selected transmitter.

# Terrestrial spectrum

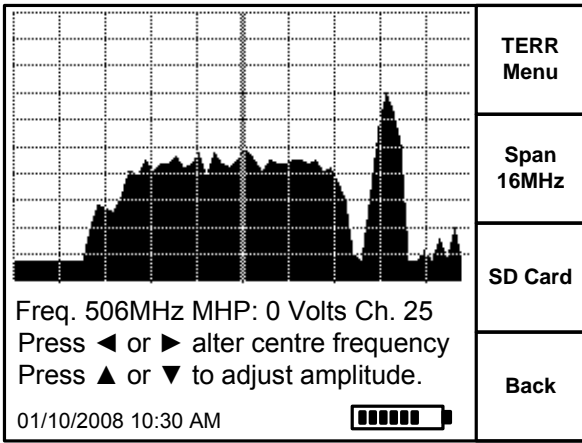

TERR Menu
Span 16MHz
SD Card
Back

Pressing **TERR Menu** will return you to the Terrestrial Menu.

Pressing **Span** cycles through the available spans of 60, 120, 240, 480, 960 and 1200MHz

Pressing **Back** will take you back to the terrestrial measuring screen.

From the terrestrial mode you can select the Spectrum Display by pressing the **Spect** soft key indicated on the right hand side of the display and you will be presented with a spectrum display similar to that shown above. For simplicity the carrier used for identification will be the centre frequency (as indicated by the vertical centre line on the spectrum display). You can adjust the centre frequency by using the left or right cursor keys and the frequency information is displayed underneath the spectrum. You can also adjust the amplitude with the up an down cursor keys so that carriers and noise floor can be seen easily.

**Note:** You can return to the satellite finding mode at any time by pressing the **Back** soft key.

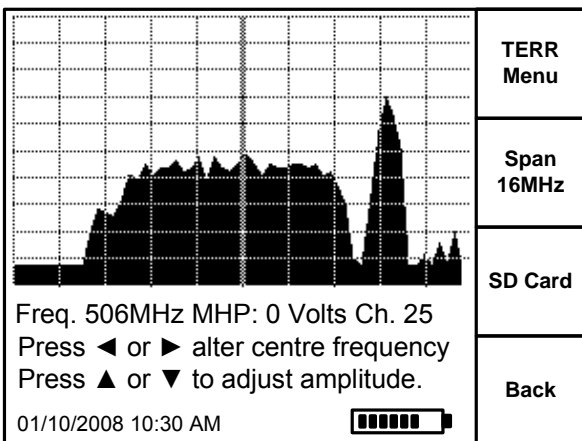

TERR Menu
Span 16MHz
SD Card
Back

Pressing **TERR Menu** will return you to the Terrestrial Menu.

Pressing **Save to SD Card** will enable you to grab a screen shot of the spectrum display saving it as a .bmp (bit map) file.

Pressing **Back** will take you back to the terrestrial measuring screen.

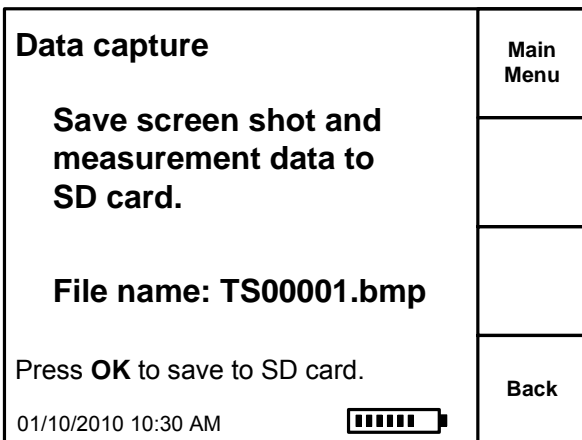

Main Menu
Back

If you choose to save the spectrum display to the SD card the whole screen is captured as a .bmp file. Once the image has been saved you will be returned to the spectrum display.

Terrestrial spectrum data capture is stored as incremental files prefixed TS and then the file number. The image is also time and date stamped.

# Terrestrial Constellation

The HD-STM can also display a terrestrial constellation diagram.

**Note:** The constellation will only operate correctly when locked on to a QAM digital carrier.

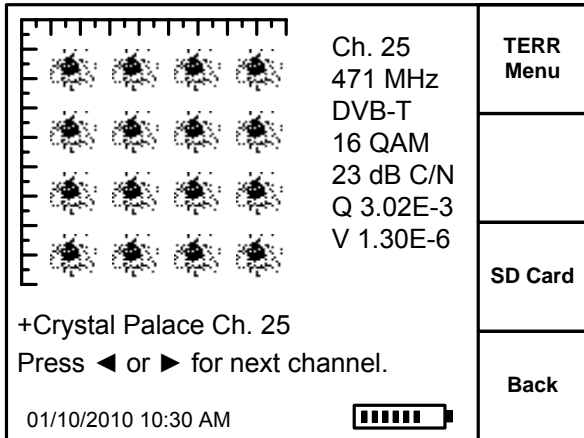

Select **TERR Menu** to select your transmitter.

Pressing **SD Card** will enable the user to grab a screen shot of the spectrum with details of the carrier if a locked condition is possible as a .bmp file.

Pressing **Back** will also return you back to the Terrestrial measuring Mode.

The example above shows the constellation diagram of a DVB-T 16 QAM service. On the right hand side of the display the receive parameters are also shown.

In the constellation mode it is also possible to save a screen shot to your SD card for the purpose of producing reports and records of installation results.

The constellation diagram can be a very useful tool for fault finding and diagnosis, as it can be used to find a point where noise has been introduced into a system where it may not be present elsewhere.

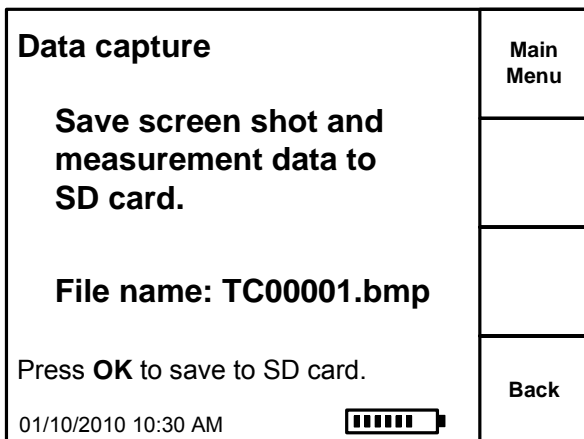

If you choose to save the constellation display to the SD card the whole screen is captured as a .bmp file. Once the image has been saved you will be returned to the constellation display.

Terrestrial constellation data capture is stored as incremental files prefixed TC and then the file number. The image is also time and date stamped.

## Terrestrial Mast Head Power

<b>Mast Head Power</b> Please select MHP voltage <b>0 Volts (Off)</b> <b>5 Volts Active Antenna</b> <b>12 Volts Mast Head Power</b>  Press ▲ or ▼ for the required voltage and press <b>OK</b> to select.	MHP 0V
	Back

By pressing the MHP button you can select the Mast Head Power Voltage from the 3 options available below.



Use the cursor keys to select which Mast Head voltage is required for your installation and press the **OK** button.

<b>UHF Step Ch. 25</b> S  46 dBuV C  22 dB Q  6.30E-3 V  3.00E-8 <b>DVB-T 506MHz **** Pass</b> Press ◀ or ▶ to select the next UHF channel. 01/10/2010 10:30 AM	TERR Menu
	MHP 12V
	Scan
	More

When mast head power is applied the MHP box will be shown in inverse.

## Scan UHF / VHF

<b>Scan +Crystal Palace</b> Freq. 482MHz Ch 22 DVB  21 More ▶ User the ◀ or ▶ buttons to select a carrier and press <b>OK</b> for more detail. 01/10/2010 10:30 AM	TERR Menu
	Log
	Back





The UHF Scan function enables you to quickly see which carriers are DVB-T (Digital) and which are Analogue for a selected transmitter. You can move the marker with the cursor keys and press the OK button to examine the carrier in more detail in this example we are looking at the Crystal Palace transmitter.

**Note:** If you are using the scan function whilst in Step Through mode only the RF power will be shown digital services are only indicated when a specific transmitter has been selected.

# Step through VHF / UHF

<b>Terrestrial Menu</b> Please select an option  <b>UK Post Code</b> <b>UK Region</b> <b>Step through UHF</b> <b>Step through VHF</b>  Press ▼ for the required option and press OK to select.  01/10/2010 10:30 AM 	Main Menu          Back
---	---



On selecting the **TERR Menu** function you can choose from selecting transmitter by **UK Post Code**, **UK Region**, **Step through UHF** or **Step through VHF** by using the cursor keys to choose your preference and the **OK** button to select.

<b>UHF Step Ch. 25</b> S  46 dBuV C  22 dB Q  6.30E-3 V  3.00E-8  <b>DVB-T 506MHz **** Pass</b>  Press ◀ or ▶ to select the next UHF channel.  01/10/2010 10:30 AM 	TERR Menu   MHP 0V  Scan  More
--	---

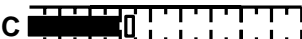

In this example on the left we have acquire a lock on a UHF DVB-T mux on channel 25 at the frequency of 506MHz.

The RF level is indicated in dBuV on the S bar, the carrier to noise is indicated on the C bar the Pre BER is shown on the Q bar (errors before correction) and Post BER is shown on the V bar, BER values are also shown numerically.

In Step Through UHF you can select channel numbers by using the left or right cursor keys.

<b>VHF Step FM 86-94</b> S  48 dBuV C  10 dB  <b>Searching</b>   Press ◀ or ▶ to select the next UHF channel.  01/10/2010 10:30 AM 	TERR Menu   MHP 0V  Scan  More
---	---

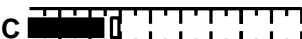
The VHF Step Through also supports FM, VHF and DAB frequencies. A lock will not be indicated but RF levels will be shown.

<b>VHF Step DAB 11B</b> S  40 dBuV C  8 dB  <b>Searching</b>   Press ◀ or ▶ to select the next UHF channel.  01/10/2010 10:30 AM 	TERR Menu   MHP 0V  Scan  More
---	---

The table on the right shows the available VHF step through selections.

- |  |
|--|
| VHF Step FM 86-94<br>VHF Step FM 94-102<br>VHF Step FM 102-110<br>VHF Step VHF D<br>VHF Step VHF E<br>VHF Step VHF F<br>VHF Step VHF G<br>VHF Step VHF H<br>VHF Step VHF I<br>VHF Step DAB 11B<br>VHF Step DAB 11C<br>VHF Step DAB 11D<br>VHF Step DAB 11A<br>VHF Step DAB 12B<br>VHF Step DAB 12C<br>VHF Step DAB 12D |
|--|



# Logging

# Data Logging

<b>Data Logging Satellite</b>  <b>Job Ref 1: Empty</b> <b>Job Ref 2: Empty</b> <b>Job Ref 3: Empty</b> <b>Job Ref 4: Empty</b> <b>Job Ref 5: Empty</b>  Press ▲ or ▼ to chose Job Ref and press OK select.  01/10/2010 10:30 AM 	SAT
	Back

When logging data the current satellite or transmitter selected will be entered as a reference in a file stored on the SD Card supplied with your meter (fitted). Select an Empty Job Ref to continue by using the cursor keys and pressing the "OK" button.

Pressing **Back** will take the user back to the last selected satellite in the Satellite Finding Mode.

<b>Data Logging Satellite</b>  <b>Please enter the Job Ref</b>  <b>Job Ref 1: A</b> ▲ <table border="1" style="display: inline-table;"> <tr> <td>A</td><td></td><td></td><td></td><td></td><td></td><td></td><td></td><td></td><td></td> </tr> </table> ▼  Press ▲ ▼ ◀ or ▶ to enter name and OK to store.  01/10/2010 10:30 AM 	A										SAT
	A										
	Letter										
	Number or Symbol										
Back											

To save time the function keys can be used to select Letters or Numbers. If no name is entered then this will default to **Job Ref 1** and sequential numbers thereafter.

Use the Up and Down Cursor keys to cycle through the available letters numbers and symbols are available via the soft keys.

The Symbols of . - + \* and can be found and the end of the Number list and **Space** is available on both.

<b>Data Logging Satellite</b>  <b>Please enter the Job Ref</b>  <b>Job Ref 1: MR SMITH</b> ▲ <table border="1" style="display: inline-table;"> <tr> <td>M</td><td>R</td><td></td><td>S</td><td>M</td><td>I</td><td>T</td><td>H</td><td></td><td></td> </tr> </table> ▼  Press ▲ ▼ ◀ or ▶ to enter name and OK to store.  01/10/2010 10:30 AM 	M	R		S	M	I	T	H			SAT
	M	R		S	M	I	T	H			
	Letter										
	Number or Symbol										
Back											

Once you have reached the end of the Job Ref name input you can store your chosen Job Ref title by pressing the "OK" button.

<b>Data Logging Satellite</b>  <b>MR SMITH</b> <b>Room 1: Empty</b> <b>Room 2: Empty</b> <b>Room 3: Empty</b> <b>Room 4: Empty</b>  Press ▲ or ▼ to chose a room press OK to select.  01/10/2010 10:30 AM 	SAT
	Add Room
	Back

On the next screen you can select a room number (this is useful for a premises that requires a multiple outlet points).

<b>Data Logging Satellite</b>  <b>MR SMITH</b> <b>Room 1</b> <b>Outlet 1: Log Entry</b> <b>Outlet 2: Empty</b> <b>Outlet 3: Empty</b> <b>Outlet 4: Empty</b>  Press ▲ or ▼ to chose an outlet. Press <b>OK</b> to view outlet 1 log data.  01/10/2010 10:30 AM 	SAT  Add Outlet   Back
--	--

When data logging you are given the option of saving to Empty slots and Viewing on previously saved slots (as well as adding too).

<b>Data Logging Satellite</b>  <b>MR SMITH</b> <b>Room 1 / Outlet 1</b> <b>V Astra 2A High 28.2E</b> <b>Crystal Palace 22</b> <b>Empty</b> <b>Empty</b>  Press ▲ or ▼ to select an entry. press <b>OK</b> to view entries.  01/10/2010 10:30 AM 	SAT   Delete Entry  Back
---	--

Press "OK" to add your entry, in this example we can see that V Astra 2A High 28.2E has been logged.

<b>Data Logging Satellite</b>  <b>MR SMITH</b> <b>Room 1 / Outlet 1</b> <b>V Astra 2A High 28.2E</b>  65.7 dBuV                      03/03/2008 12.6 dB C/N                    13:47:10 QBER 1.7881e-006 VBER 0.000e+000  Press ◀ or ▶ to view log entries.  01/10/2010 10:30 AM 	SAT   Delete Entry  Back
---	--

From here the you can also step through all the entries made for this particular Job Ref in Room / Outlet sequence.

<b>Data Logging Satellite</b>  <b>MR SMITH</b> <b>Room 1 / Outlet 1</b> <b>V Astra 2A High 28.2E</b> <b>Crystal Palace 22</b> <b>Empty</b> <b>Empty</b>  Press ▲ or ▼ to select an entry. press <b>OK</b> to log data.  01/10/2010 10:30 AM 	SAT  Add Log Entry   Back
---	---

The Logging function is cross platform (Satellite or Terrestrial) and when a log entry is made the data is always taken from the last acquired lock.



# Driver Installation

# Driver installation

Before we can load new selections downloaded from the Horizon web site it is necessary to load the drivers supplied on the CD Rom on to your computer. This procedure is explained step by step below.

**Insert the supplied CD Rom into your computer now so that the driver installation can be complete easily.**

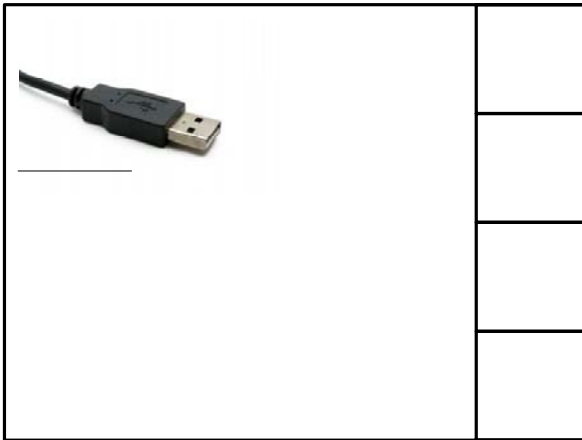

Connect your meter to you PC with the USB cable supplied. Then press the **On** button and the screen will power up with a USB connector symbol as illustrated in the screen shot on the left.

The found new hardware wizard will appear on your computer.

**Please note:** If there is no activity on the USB port for 2 minutes the meter will automatically power down.



Your computer will detect that a device is connected to your computer.

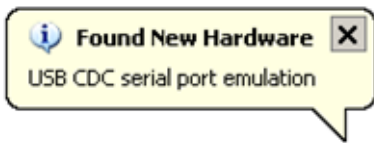

The hardware (USB CDC Serial Port) will be detected.



The “**Found New Hardware**” wizard will appear, select “**Yes, this time only**” and then click “**Next >**”

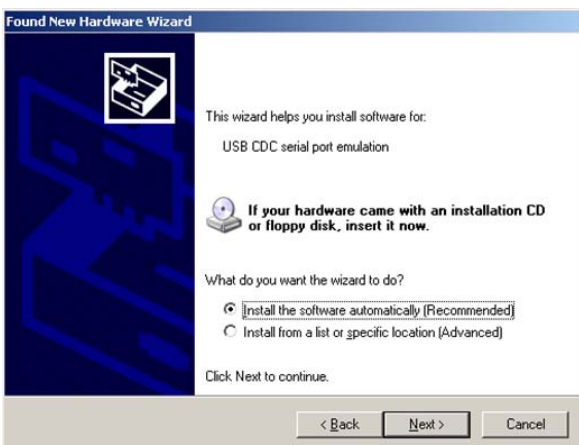

Select “**Install the software automatically [Recommended]**” option and click “**Next >**”

Continued...

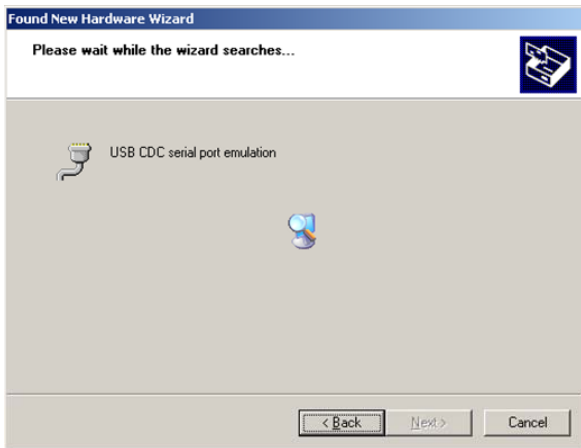

Your computer will now search for the required driver files. (Please insure that the CD Rom supplied is inserted in your computer).

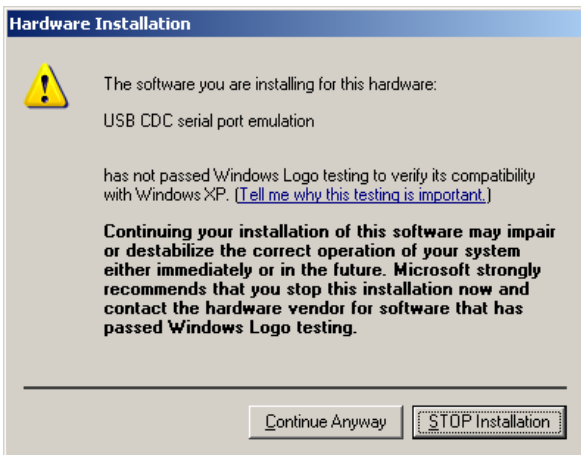

Once the driver has been located you will need to click "**C**ontinue Anyway" to proceed.



Once the Found New Hardware wizard has completed click on "**F**inish" to close the program.



A pop up will appear above the tool bar to inform you that this procedure has been completed successfully.

**Note:** The required drivers are also available as a free download directly from the Horizon Global Electronics Ltd web site [www.horizonhge.com](http://www.horizonhge.com)



# Web Downloads

# Web Downloads Satellite

Various downloads are available for the HD-STM from the Horizon Global Electronics web site [www.horizonhge.com](http://www.horizonhge.com) from the downloads section you can update your satellite list and terrestrial transmitter selections.

### Satellite Transponders

**Use a predefined list**

1. Select Region
2. Select List

**Satellite Update Mode**

Do Not Update  
 Use List  
 Create your own

**Create your own download list**

1. Enter your list name
2. Select transponders

Astra2Conect t3	
Astra2Conect t21	
Astra2Conect t27	
Astra2Conect t31	
Astra2Conect t35	
Astra2Conect t61	<input type="checkbox"/>
Avanti Tp61 34.5	
Avanti Tp64 34.5	
Avanti Tp78 34.5	
Custom DSS 1	
Custom DSS 2	
Custom DSS 3	

### Terrestrial Transmitters

Select Region

**Terrestrial Update Mode**

Do Not Update  
 Select Region

**Email Address**

For satellite you can choose to download predetermined lists or build a list from the transponders available. For terrestrial you can select a region and download the complete transmitter list. You can also chose to download directly from the site or have the loading program sent to your email address.



# File Transfer

## File Transfer

---

Now that you have downloaded your desired files we are ready to transfer them to your HD-STM meter. Ensure that you have already installed the drivers for your meter on your computer before proceeding. Connect your HD-STM meter via the USB lead supplied to your computer.

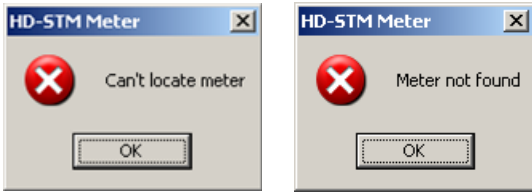

**Note:** if the required drivers have not been installed then these errors could occur.

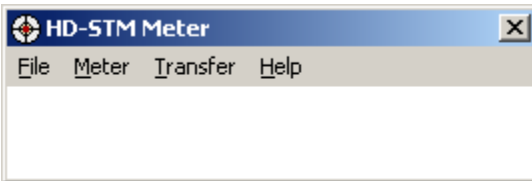

Unzip and double click the target icon of the HD-STM loading program that you downloaded previously from the Horizon web site.

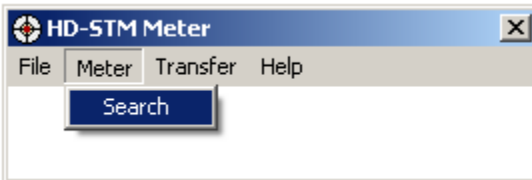

Select **Meter** and then **Search** to check which com port is being used, this will put the meter into program mode.

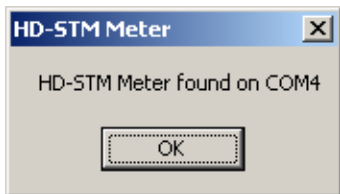

Click **OK** on the pop-up showing the com port in use.

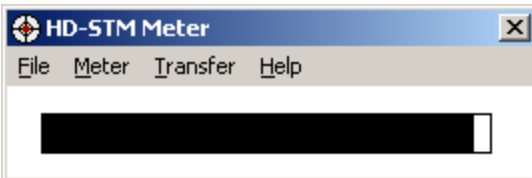

Click **Transfer** to send the data to your meter. On clicking Transfer the meter display will change to "Program mode".



Click "OK" once the transfer is complete, close the program and disconnect your meter.



### Troubleshooting:

Should a "Meter found but can't open serial port" error occur please disconnect the USB lead and start the loading procedure from the beginning.



# SD Memory

## SD Card Management

<p><b>SD Card Management</b></p> <p><b>Import Meter Settings</b></p> <p><b>Export Meter Settings</b></p> <p><b>Import Job sheets</b></p> <p><b>Export Job Sheets</b></p> <p>Press ▲ or ▼ to choose and <b>OK</b> to select. Press <b>Back</b> to return to Setup.</p>	<p>Main Menu</p> <p> </p> <p> </p> <p>Back</p>
---	--

The HD-STM features an SD card slot for the storing of screen from Spectrum and Constellation displays along with logged measurements that you may have stored.

The Import and Export Meter Settings will enable you to save and load the current state of the meter setup, which included measurement preferences along with display and beeper settings.

<p><b>SD Card Management</b></p> <p><b>Import Meter Settings</b></p> <p><b>Export Meter Settings</b></p> <p><b>Import Job sheets</b></p> <p><b>Export Job Sheets</b></p> <p>Press ▲ or ▼ to choose and <b>OK</b> to select. Press <b>Back</b> to return to Setup.</p>	<p>Main Menu</p> <p> </p> <p> </p> <p>Back</p>
---	--

The Import and Export Job Sheets function will enable you to download blank job sheets and upload completed job sheets with pre and post installation measurement values.

<p><b>SD Card Export Job Sheets</b></p> <p><b>Job 060608.jsf</b></p> <p>Press ▲ or ▼ to choose and <b>OK</b> to export. Press <b>Back</b> to return to Setup.</p>	<p>Main Menu</p> <p> </p> <p> </p> <p>Back</p>
---	--

Job sheets are saved and loaded as .jsf files.

<p><b>SD Card Export Job Sheets</b></p> <p><b>Saving Job Sheet to SD card to meter please do not remove from slot or switch off your meter.</b></p> <p><b>Please wait...</b></p>	<p> </p> <p> </p> <p> </p> <p> </p>
--	-------------------------------------

During reading or writing files to the HD-STM SD card the screen will advise you as to the current operation.



# System Warnings

## System messages

<p><b>SYSTEM WARNING</b> <b>Satellite</b></p> <p><b>LNB Short Circuit</b> <b>Shutting Down</b></p> <p>Remember to disconnect your cable before switching your meter on again</p>	

**Your HD-STM is designed with circuit protection and in the instance of a fault condition the meter will shut down to protect itself.**

This message is seen if there is a short circuit condition when installing satellite system. Check you cable and connectors, it is also worth checking the replaceable F barrel socket on your meter for any metallic debris that could cause a short.

<p><b>SYSTEM WARNING</b> <b>Satellite</b></p> <p><b>LNB Over Current</b> <b>Shutting Down</b></p> <p>Remember to disconnect your cable before switching your meter on again</p>	

This error message indicates that too much current is being drawn by the LNB assembly and the meter has shut down to protect itself. This could occur on some integral multi LNB assemblies.

<p><b>SYSTEM WARNING</b> <b>Terrestrial</b></p> <p><b>Antenna Short Circuit</b> <b>Shutting Down</b></p> <p>Remember to disconnect your cable before switching your meter on again</p>	

This message is seen if there is a short circuit condition when installing a terrestrial antenna. Check you cable and connectors, it is also worth checking the replaceable F barrel socket on your meter for any metallic debris that could cause a short.

<p><b>SYSTEM WARNING</b></p> <p><b>IC2 Error</b> <b>Shutting Down</b></p> <p>Remember to disconnect your cable before switching your meter on again</p>	

This message is seen if there is a communication error between the tuner assembly and the mother board. This type of error can occur if the battery is exhausted or in extremely cold temperature conditions. In winter time please insure that your meter is not left in the vehicle overnight as temperatures can fall rapidly and have an impact the battery performance.

## System warnings

---

<p><b>SYSTEM WARNING</b> <b>Satellite</b></p> <p><b>LNB Short Circuit</b> <b>Shutting Down</b></p> <p>Remember to disconnect your cable before switching your meter on again</p>	

In the event of a fault condition system warnings will be displayed.

This warning indicates that there is a short circuit when connecting to the LNB.

<p><b>SYSTEM WARNING</b> <b>Satellite</b></p> <p><b>LNB Over Current</b> <b>Shutting Down</b></p> <p>Remember to disconnect your cable before switching your meter on again</p>	

This warning indicates that the LNB assembly is drawing too much current.

<p><b>SYSTEM WARNING</b> <b>Terrestrial</b></p> <p><b>Antenna Short Circuit</b> <b>Shutting Down</b></p> <p>Remember to disconnect your cable before switching your meter on again</p>	

This warning indicates that there is a short circuit when connecting to the antenna.

<p><b>SYSTEM WARNING</b></p> <p><b>IC2 Error</b> <b>Shutting Down</b></p> <p>Remember to disconnect your cable before switching your meter on again</p>	

An IC2 error is generated when there is a communication problem between the tuner board assembly and the main processor. Very low battery power or extreme temperature can cause this type of error.

# Specification

---

## Connections

- LNB / VHF / UHF input via replaceable F barrel
- DC 12V input for vehicle aux charge socket
- 2 Amp fused 2.1 mm jack car charger supplied
- Figure of 8 A/C mains voltage input to internal battery charger
- USB Interface for web downloads
- SD Memory Card Slot for data logging and setup back-up

## Battery

- Advanced Lithium Polymer (Li-Po) 2400mAh 14.8V battery assembly
- Cells UL listed: MH27673
- Cell type: SL704776
- Replacement part number: BP1500
- 2 and 4 pin connectors

## Satellite

- RF Input range: 950 – 2150MHz 40dBuV to 110dBuV (approximate)
- LNB Supply Voltages: 13V Vertical 18V Horizontal (21V SCR)
- LNB Short Circuit Protection: @ 750mA maximum current limiter
- Transponder memory: Up to 4000 definitions
- Modulation supported: DVB-S QPSK, DSS, DVB-S2 QPSK, 8PSK
- Satellite Bands: C, Ku and Ka
- Input dynamic range: -70dBm to 0dBm
- RF Level accuracy in dBuV +/- 1dB
- Input impedance: 75 Ohms
- Symbol rate: 1Msps – 45Msps
- Data logging
- Screen capture of spectrum or constellation display
- MER (Modulations Error Rate) expressed in dB
- C/N (Carrier to Noise) expressed in dB

## Terrestrial

- Variable bandwidth to 8MHz
- Frequency range 49MHz (VHF) to 861MHz (UHF) Analogue and Digital
- Rapid scan of full VHF and UHF bands
- Input levels -92dBm to -20dBm
- QAM constellation display
- Select RF level as dBm dBuV or dBmV
- Automatic 2k/8k constellation detection
- Analogue measurements, Video and Audio levels
- Data logging
- Screen capture of spectrum or constellation display
- Masthead Amplifier power 5V or 12V 100mA (max) supply

\* All specifications are subject to change without notice. E&OE

# Conditions of Warranty

---

The following warranty terms and conditions apply only to Horizon Global Electronics Ltd products that have been supplied with a warranty.

## I. General Conditions of Warranty

### 1. General

This warranty covers defects relating to workmanship and manufacture in Horizon products. The period during which this warranty is valid and during which claims against the warranty can be made to Horizon must be in accordance with the following terms in order to be considered eligible:

- Is effective from the date of purchase or receipt of the Horizon product from an authorised seller of Horizon products; and
- Expires at the end of the warranty period specified on the warranty card provided with the product.

For the warranty to be valid, you must:

- provide suitable evidence of purchase, a copy of the original purchase receipt from an authorised seller of Horizon products is preferred; or
- Register your product within 28 days of purchase either online at [www.horizonhge.com](http://www.horizonhge.com) or by completing and returning the pre-paid registration card included with the product. Please keep the original purchase receipt and the warranty card in a safe place. Horizon and its authorised sellers reserve the right to refuse a repair under warranty or a warranty confirmation if a proof of purchase [or registration of purchase] cannot be established, or has not been, submitted.

When it is necessary to return your product for repair please ensure that your product is suitably packed for transportation. Provided that your product is still within warranty (please check the duration of the warranty period as described above) and is eligible for repair or replacement under the terms of the warranty, to return your product, please telephone Horizon on the service hotline number.

Horizon shall bear the costs of postage and packaging for returning the product and the transportation risk. However, if following examination of the defective product in question, Horizon, in its reasonable opinion, considers that the defect has been caused by:

- damage caused in transit as a result of your negligence in packaging of the product; and/or
- otherwise than in accordance with the terms of this warranty; This warranty shall be void and you may be required by Horizon to reimburse Horizon for the reasonable costs of postage and packaging before Horizon will return the product to you. If so and you would still like Horizon to repair or replace the product, Horizon may do so but you will be charged Horizon's standard rates for repair and replacement for this service.

Before returning the product, please contact Horizon via the service hotline or via the internet ([www.horizonhge.com](http://www.horizonhge.com))... Please submit a letter containing as much detailed information as possible and, a full description of the defect or fault.

This should include:

- a description of the fault;
- when it occurred, how long it has been evident and how frequently it occurs;
- any error message(s) displayed when using the product;
- a description of the circumstance(s) and conditions in which the fault occurs; and
- whether it is an intermittent or persistent fault;

This will greatly assist Horizon in identifying the defect, when submitted together with the defective product.

Horizon does not accept any liability for any additionally submitted material(s) which were not supplied with the original Horizon product.

This warranty does not affect your statutory rights in any way and is subject to the applicable legal statutes of the country where the product was sold to you by an authorised Horizon seller.

Non critical failures that fall within industry specified tolerances e.g. noise; LCD pixels are not covered by this warranty. Please consult the appropriate section in your user or instruction manual for this product for exact specifications and tolerances.

The warranty does not cover errors relating to the playback of data media in an incompatible format or created with unsuitable software.

If it is found during repair or assessment that the defect concerned is not covered under warranty, Horizon reserves the right to invoice you for all reasonable costs incurred by Horizon. These costs will be in relation to the return of the product, including reasonable administration costs, plus reasonable costs for materials used and labour provided when repairing or replacing the product. This is subject to Horizon providing you with an estimate for carrying out such work prior to costs being incurred and that you have accepted the estimate.

You are entitled to seek independent advice or consultation relating to your product or any of Horizon's findings. Horizon will not be liable for any costs incurred to you when doing so.

Continued...

## 2. Exclusion from warranty

To the extent permitted by law, this warranty shall be void in the event that defects or loss caused by:

- failure and damage resulting from the operation of the product in an environment other than that recommended in the accompanying user or instruction manual;
- accidental damage;
- use other than in accordance with the accompanying user or instruction manual;
- modifications, conversions, expansions, maintenance and/or repairs made to the Horizon product by unauthorised repairers or use of unauthorised third party parts;
- negligence;
- virus attack or software errors; or
- Improper transportation or packaging during return of the product.
- Tampering or breaking of warranty seals

This warranty will also be considered void if labels or serial numbers of the product or of a component of the product are modified or made illegible.

To the extent permitted by law, Horizon shall; only be responsible for losses which are a reasonably foreseeable consequence of the relevant defect in the product; Horizon will not be responsible for any costs incurred in relation to software configuration; economic loss; loss of opportunity; loss of income; or loss of data or software arising out of its repair or replacement of a Horizon product under this warranty

### Scope

Subject to any exclusions set out within this warranty, where there is a defect in your Horizon product covered by this warranty, Horizon will repair or replace the Horizon product. The decision whether to repair or replace the product will be made solely at the discretion of Horizon. Horizon may, in its own discretion, replace the product returned for repair under warranty with a replacement product that is either identical or, in the event that such product(s) are no longer available, a product of equal or superior specification and quality.

No warranty is given for batteries or rechargeable batteries or for consumable materials subject to wear and tear, i.e. for parts which have to be replaced periodically during the normal use of the product.

Software supplied with Horizon products will function without interruption, will be free from errors or that it will fulfil your requirements. Horizon does not guarantee the 100% accuracy of the data provided as part of the software.

It may be necessary to delete all data in the product in order to repair the Horizon product. PLEASE MAKE SURE THAT YOU HAVE A BACKUP COPY OF ALL DATA ON THE PRODUCT BEFORE RETURNING THE PRODUCT TO HORIZON. To the extent permitted by law, Horizon excludes all liability for loss of data and Horizon recommends in all cases that you back up all data on your Horizon product before returning the product to Horizon.

## LIMITED WARRANTY

Horizon will, at our option, repair or replace any HD-STM found to be defective in manufacture within the warranty period (2 years).  
Accessories and batteries are not covered by warranty.

The warranty period is determined by the date of HD-STM purchase.  
Keep your receipt as proof of purchase. Otherwise the warranty is determined by date of manufacture.

This warranty does not apply to damage caused by accident, misuse, or tampering with the unit or seals. This does not affect your statutory rights.

## DECLARATION OF CONFORMITY

**Manufacturer:** Horizon Global Electronics Ltd.

**Address:** First Floor Office, Allen House, Edinburgh Way, Harlow, Essex CM20 2HJ

Declares that the Horizon HD-STM complies with the following directives and standards.

Safety EN610 10-1:2001

EMC 61326:1997

FCC Part 15: Class A

All Horizon products are ROHS compliant.

Technical Department  
Horizon Global Electronics

August 2010



## CONTACT DETAILS

### Horizon Global Electronics Ltd.

First Floor Office  
Allen House  
Edinburgh Way  
Harlow  
Essex  
CM20 2HJ

Tel: +44 (0)1279 417 005  
Fax: +44 (0)1279 417 025  
Email: [sales@horizonhge.com](mailto:sales@horizonhge.com)  
Web: [www.horizonhge.com](http://www.horizonhge.com)

Producer ID for the purposes of WEEE regulations: WEE/BB0191UV